

# Straight Tube

Tube Size OD	SPD Part #	Wall Thickness	Materials Available
<b>1.00</b>	ST10020	.035	304
	ST10018	.049	1008, 304, 321
	ST10016	.063	1008, 304
<b>1.125"</b>	ST11320	.035	304
	ST11318	.049	1008, 304, 321
	ST11316	.063	1008, 304
<b>1.25"</b>	ST12520	.035	304, 321
	ST12518	.049	1008, 304, 321
	ST12516	.063	1008, 304,
<b>1.375"</b>	ST13820	.035	304, 321
	ST13818	.049	1008, 304, 321
	ST13816	.063	1008, 304
<b>1.50"</b>	ST15020	.035	304, 321
	ST15018	.049	1008, 304, 321
	ST15016	.063	1008, 304, 321, 6061
<b>1.625"</b>	ST16320	.035	304, 321
	ST16318	.049	1008, 304, 321
	ST16316	.063	1008, 304, 321
<b>1.75"</b>	ST17520	.035	304, 321
	ST17518	.049	1008, 304, 321
	ST17516	.063	1008, 304, 321, 6061
<b>1.875"</b>	ST18820	.035	304, (321 Special Order)
	ST18818	.049	1008, 304, 321
	ST18816	.063	1008, 304, 321
<b>2.00"</b>	ST20020	.035	304, 321
	ST20018	.049	1008, 304, 321
	ST20016	.063	1008, 304, 321, 6061
<b>2.125"</b>	ST21320	.035	304, 321
	ST21318	.049	1008, 304, 321
	ST21316	.063	1008, 304
<b>2.25"</b>	ST22520	.035	304, 321
	ST22518	.049	1008, 304, 321
	ST22516	.063	1008, 304, 321, 6061
<b>2.375"</b>	ST23820	.035	304
	ST23818	.049	1008, 304, 321
	ST23816	.063	1008, 304
<b>2.50"</b>	ST25020	.035	304, 321
	ST25018	.049	1008, 304, 321
	ST25016	.063	1008, 304, 321, 6061



# Straight Tube



Tube Size OD	SPD Part #	Wall Thickness	Materials Available
2.625"	ST26320	.035	321
	ST26318	.049	1008, 304
	ST26316	.063	1008, 304
2.75"	ST27518	.049	1008, 304, 321
	ST27516	.063	1008, 304
3.00"	ST30020	.035	321
	ST30018	.049	1008, 304, 321
	ST30016	.063	1008, 304, 321, 6061
3.25"	ST32516	.063	1008, 304
3.50"	ST35020	.035	321
	ST35018	.049	1008, 321
	ST35016	.063	1008, 304
4.00"	ST40020	.035	321
	ST40018	.049	321
	ST40016	.063	1008, 304
4.50"	ST45016	.063	1008, 304
5.00"	ST50016	.063	1008, 304

## Tube Extensions

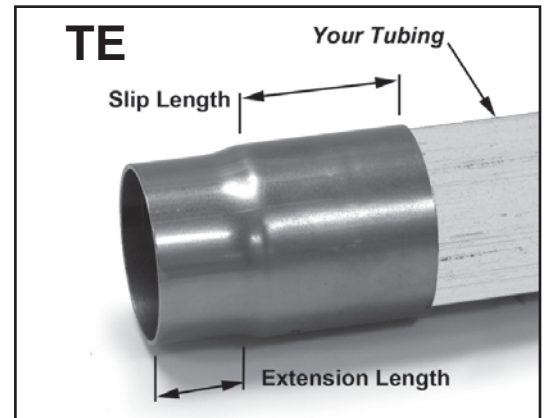
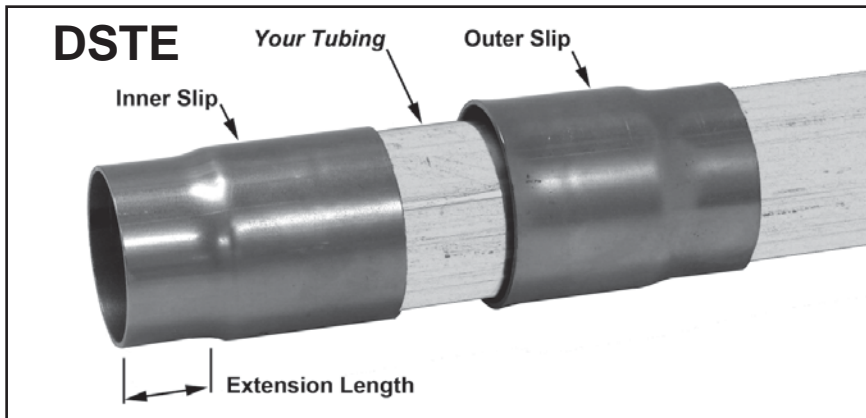

**DSTE's** offer a positive seal without the added outer dimension of a flange or clamp.

**TE's** can be used can be used for track or dyno tuning.

Tube extensions are available in most tube sizes and lengths.

(See page 16 for retaining hardware)

